

ELECTRICAL ORDER FORM

Advance Payment Deadline Date: 06/03/18

E M



ELECTRICAL EXHIBITION SERVICES
 129 Sylvester Road, So. San Francisco, CA 94080
 Ph: (650) 225-0900 Fax: (650) 225-0950
 sanfrancisco@edlen.com

COMPANY:		BTH #	
EVENT:	Fashion Market Northern California		
FACILITY:	San Mateo Event Center		
DATES:	June 24 - 26, 2018	EVENT#	068010SF

IMPORTANT SAFETY ISSUES

All exhibitor extension cords must be a minimum of 14 gauge, 3 wire and grounded. Two (2) wire extension cords also referred to as "zip cords" are not allowed by the Fire Marshall. All exposed non-current carrying metal parts of fixed equipment which are liable to be energized shall be grounded.

ELECTRICAL PACKAGE - Power that comes with exhibitor booth space
 Please note that each 10x10 booth space receives 500 watts of power for exhibitor supplied lighting. In the event your total power requirements exceeds this amount, please order the additional power below.

ADDITIONAL ELECTRICAL POWER Approximately 120V/208V A.C. 60 Cycle

	QUANTITY	ADVANCE PRICE Thru 06/03/18	REGULAR PAYMENT Starting 06/04/18	TOTAL COST
0 - 500 WATTS	_____	107.00	161.00	_____
501 - 1000 WATTS	_____	196.00	294.00	_____
1501 - 2000 WATTS	_____	269.00	404.00	_____

LIGHTING RENTALS
 Edlen offers a variety of additional lighting options to light up your exhibit & product line. Please note that power is included with the light rental

50 Watt MR 16 Arm Light mounted to exhibit



TRUSS AND LIGHTING PACKAGES



10 linear feet = (4) lights 20 linear feet = (8) lights 40 linear feet = (14) lights
 15 linear feet = (5) lights 30 linear feet = (10) lights **(Lights are 50 Watt Spot lights)**

LIGHTS & MATERIAL RENTAL	QUANTITY	ADVANCE PAYMENT PRICE	REGULAR PAYMENT PRICE	TOTAL COST
Additional 50 Watt Spot Lights.....	_____	26.00	36.00	_____
50 Watt MR 16 Arm Light	_____	100.00	150.00	_____
10 Foot Truss (4 lights)	_____	189.00	189.00	_____
15 Foot Truss (5 lights)	_____	243.00	243.00	_____
20 Foot Truss (8 lights)	_____	297.00	297.00	_____
30 Foot Truss (10 lights)	_____	352.00	352.00	_____
40 Foot Truss (14 lights)	_____	406.00	406.00	_____

Power Strips Qty _____ 23.00 Total: _____ Extension Cords 15 ft & 25 ft Qty _____ 23.00 Total: _____

PLACE TOTAL HERE
PRINT NAME:
AUTHORIZED SIGNATURE:
EMAIL: PHONE:
TERMS & CONDITIONS: I agree in placing this order that I have accepted Edlen's payment policy and the terms and conditions of contract.

METHOD OF PAYMENT

Advance Payment Deadline Date: 06/03/18



The Power People

ELECTRICAL EXHIBITION SERVICES

129 Sylvester Road, So. San Francisco, CA 94080
 Phone: (650) 225-0900 Fax: (650) 225-0950
 sanfrancisco@edlen.com

EXHIBITOR:		BTH #	
EVENT:	Fashion Market Northern California		
FACILITY:	San Mateo Event Center		
DATES:	June 24-26, 2018	Event #068010SF	

FINANCIALLY RESPONSIBLE COMPANY

COMPANY NAME:		PHONE:	
ADDRESS:		FAX:	
CITY:	ST:	ZIP:	
COUNTRY:	CELL #:		
EMAIL:			

METHOD OF PAYMENT

All transactions require a credit card on file with proper authorization. In addition to checks, Edlen also accepts American Express, Mastercard, Visa, Discover, ACH and Wire Transfers. Indicate form of payment below.

ACH ELECTRONIC PAYMENT TRANSFER

Wells Fargo ABA# 121000248 Acct: 4122636046
 3800 Howard Hughes Parkway, Las Vegas, NV 89169
 Phone: 800.289.3557

Please note the financial institution MUST be based in the US. In order to avoid a transfer fee, you must notify the financial institution that you wish to make an ACH electronic payment transfer.

BANK WIRE TRANSFER INFORMATION *

Bank transfer to Wells Fargo
Wire Transfer:
 ABA#: 121000248 Acct: 4122636046
International Wire Transfer:
 Swift Code: WFBIUS6S Acct: 4122636046

* Please reference the Event # listed above and your Booth # on all electronic payments.

*** \$50 processing fee MUST be included with transfer.**

CREDIT CARD

For your convenience, we will use this authorization to charge any remaining balances on your account prior to event closing. A copy of final charges will be sent to the email address provided in the payment information section.

VISA MASTERCARD AMEX DISCOVER

COMPANY CHECK

Please make check payable to: Edlen Electrical. All foreign checks must be drawn on U.S. Banks only. For those booths that require labor a credit card must be on file. Please reference the Event # listed above on your remittance.

CHECK AND CREDIT CARD INFORMATION

COMPANY NAME:	
CHECK #:	
CREDIT CARD NUMBER:	EXP DATE:
CARD HOLDER SIGN:	PRINT NAME:
EMAIL: THIRD PARTY PAYMENT? YES or NO	

CREDIT CARD ADDRESS INFORMATION IF DIFFERENT THAN INFORMATION ABOVE

ADDRESS:	CITY:	ST:	ZIP:
----------	-------	-----	------

SERVICE TOTALS

1. BANK WIRE TRANSFER PROCESSING FEE	
2. ELECTRICAL ORDER	
3. ESTIMATED LABOR	
4. LIGHTING ORDER	
5. PLUMBING ORDER	
TOTAL DUE	

AUTHORIZATION

AUTHORIZED SIGNATURE ABOVE	
PRINT NAME ABOVE	TODAY'S DATE ABOVE

By signing and placing this order, I accept all payment policies and the terms and conditions outlined on all completed service order forms.

TERMS & CONDITIONS

1. Order with payment & floor plan (for island booths or any booth requiring distribution of electrical services) must be received no later than the deadline date on the front of this form for advance payment rates to apply. Orders faxed or mailed without payment and required floor plan will not be guaranteed advance rates. Orders received after the deadline date will be charged at the regular rate. A purchase order or photocopy of a check are not considered valid forms of payment for securing advanced rate.
2. In the event order totals are calculated incorrectly, Edlen reserves the right to make the necessary corrections and charge the corrected amount. Exhibitors will be notified by email or fax of any such corrections.
3. Outlet rates listed include bringing the services to one location in island booths and to one location at the rear of in-line and peninsula booths.
4. Outlet rates listed **do not** include the connection of any equipment, special wiring, or distribution of the outlets to other location's within the booth space. Distribution to all other locations *regardless of booth type* require labor and is performed on a time and material basis. Exhibitors are invited to contact the local Edlen office to discuss any additional costs that may be incurred.
5. A separate outlet must be ordered for each location where an electrical service is required. 5 amps or 500 watts is the minimum amount of power that can be ordered for any one location. Power must be ordered according to peak amperage ratings.
6. Island booths - If a floor plan showing main power location is not submitted to Edlen prior to our first move-in date, Edlen will deliver the power to the most convenient location.
7. Labor rates are based on current wage scales and are subject to change in the event of a wage increase after rates have been published. A minimum charge of (1) hour labor will apply for all installation work. The removal of this work will be charged a minimum of 1/2 hour or 1/2 the total time of installation.
8. In the event 1000 watt overhead quartz lights cannot be mounted to existing catwalks in the convention hall, lift and labor charges will apply. Please contact our local office to discuss any additional charges.
9. Edlen employees are authorized to cut floor coverings when essential for installation of services unless otherwise directed.
10. Edlen is the exclusive provider of all material and equipment used in the distribution of temporary electrical services throughout the exhibit hall including the exhibitors booth space. This material is provided on a rental basis ONLY and remains the property of Edlen. It shall be removed only by Edlen employees.
11. Any extension cords or power strips ordered on the front of this form should be picked up at the service desk. Credit will not be not issued for unused items.
12. Standard wall and other permanent building utility outlets or sockets are not part of a booth space and may not be used by exhibitors unless electrical services have been ordered through Edlen.
13. All equipment regardless of source of power, must comply with federal, state and local codes. Edlen reserves the right to inspect all electrical devices and connections to ensure compliance with all codes, for which labor charges can be incurred. Edlen is required to refuse connections where the Exhibitor wiring or equipment is not in accordance with electrical codes.
14. All electrical equipment must be properly tagged and wired with complete information as to the type of current, voltage, phase, cycle, horsepower, etc., required for operation.
15. All Exhibitors' cords must be a minimum of 14 gauge, 3 wire and grounded. Two (2) wire extension cords are not allowed. All exposed, non-current carrying metal parts of fixed equipment which are liable to be energized, shall be grounded.
16. Payment in full must be rendered during the event. Exhibitors ARE NOT billed for services provided. Services may be interrupted if payment is not received.
17. Credit will not be given for services installed and not used. All orders are subject to a 25% cancellation fee if cancelled in writing & received by Edlen within 14 calendar days prior to show opening. Except sales tax, Edlen will not refund overpayment in amounts less than \$50.00 unless specifically requested in writing.
18. Claims will not be considered or adjustments made unless filed in writing by Exhibitor prior to the close of the event.
19. Exhibitor holds Edlen harmless for any and all losses of power beyond Edlen's control, including, but not limited to, losses due to utility company failure, permanent power distribution failure, power failure caused by vandalism, faulty Exhibitor equipment or overloads caused by Exhibitor.
20. It is agreed that in the event it becomes necessary to turn this matter over to an attorney for collection, or to file a lien, or foreclosure, or otherwise, Exhibitor will pay Edlen its attorney fees or applicable agency fees.
21. A service charge of 1.5% per month on any unpaid balances will be assessed starting 10 days after date of invoice. A \$25.00 service charge will be assessed for all returned checks and credit cards. Exhibitor agrees to reimburse Edlen for all applicable rental taxes.
22. By signing this and/or the Method of Payment form, exhibitor hereby agrees to all terms and conditions on this order form.

COMMONLY ASKED QUESTION - WHERE WILL MY OUTLET BE LOCATED?

Outlets are located as depicted below for inline & peninsula booths. All other locations require labor on a time & material basis. Exhibitors with hard wall booths must make arrangements with Edlen to bring power inside the booth on a time and material basis.

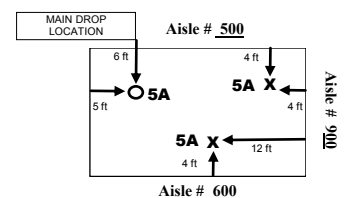
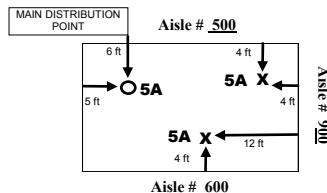
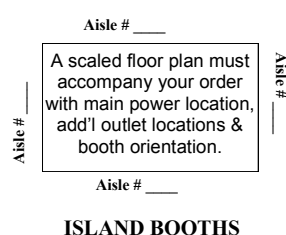
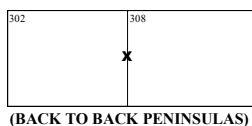
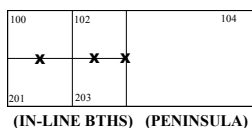

**FOR OTHER COMMONLY ASKED QUESTIONS VISIT OUR WEB SITE @ WWW.EDLEN.COM
OR CALL THE NUMBER ON THE FRONT OF THIS FORM.**